

CYKEO-GYP1

RFID HARD DISK CABINET



The CYKEO-GYP1 RFID Secure HDD Cabinet revolutionizes physical data management with military-grade 1.2mm carbon steel construction and 13.56MHz RFID technology. Featuring dual-authentication via fingerprint/ID card and real-time LED status monitoring, it ensures 24/7 chain-of-custody tracking for government agencies, financial institutions, and research centers requiring NIST-compliant media storage.

- 21.5-inch capacitive touch screen with 1920 × 1080 resolution
- RFID technology 13.56MHz optional, support protocol extension
- Multiple interfaces: RJ45, support wifi, 4G, alarm input etc
- Support multiple cabinets in parallel, optional Windows / Android system
- Saving manual inventory time and warehouse registration procedures, improve management and control efficiency, grid can be extended
- Product appearance, function, protocols etc support customization

● Specification

Model	CYKEO-GYP1
 RF SPECIFICATION	
Identification Method	HF
Frequency Range	13.56MHz
Protocol	ISO 15693, ISO 14443A
Function	RFID read function, Multiple label identification, Label data filtering, Quantity statistics
Product Capacity	120 pcs
 HARDWARE SPECIFICATION	
System	Windows / Android (optional)
Hardware	I5 CPU, 4G RAM, 128G ROM / RK3399 CPU, 4GRAM, 16G ROM (optional)
Display	1920 x 1080, 22-inch capacitive touch screen (optional)
Communication	RJ45 10 / 100Mbps
 FUNCTION SELECTION	
RFID Card Reader	Standard
Face Recognition	Optional
Bar Code	Optional
QR Code	Optional
Sound Light Alarm	Optional
Fingerprint Recognition	Optional

- **Related Model**

CYKEO-GZF

- **Common Solution**

Smart Library, Archival Room, Tool Room, Supermarket, etc.

- **Dimension**

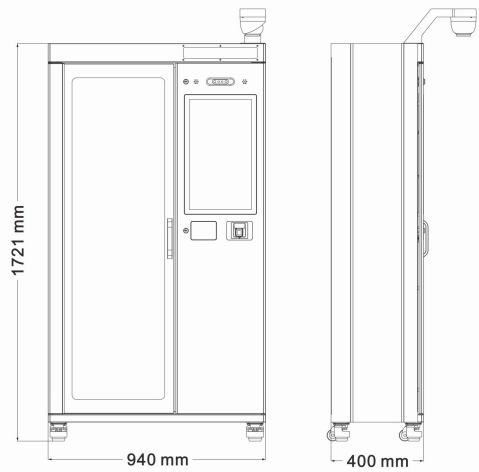

Unit : mm (inch)
 Weight. : about 150
 kg

- **Accessory**

serial number	name	units	quantity
1	power supply	pcs	1



RFID IoT Application



Need Advice



Subscribe

Follow us: [Cykeo](#)



Headquarters

Cykeo Information Technology CO., LTD.
16th floor, Building B2, Yunzhi Science Park, Guangming District,
Shenzhen 518107, China

Factory

Shenzhen, Dongguang, Hefei

Subsidiary

Hefei Jianshen InformationTechnology Co.,
LTD.
Cykeo Information Technology (Shandong) Co., LTD.
Cykeo Information Technology (Chengdu) Co., LTD.
Cykeo Core Information Technology (Shanghai) Co., LTD.